

[Carton Clamp]

with integral sideshift, rigid arm

The Meyer rigid arm carton clamp, is suitable for handling side by side, cartons and appliances such as washing machines, refrigerators, televisions, etc. The thin profile rubber faced pads allow for close stacking and break out when order picking.

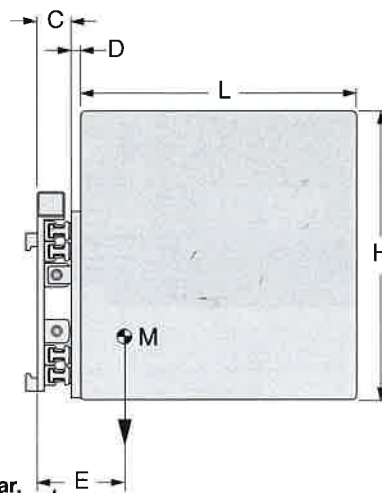
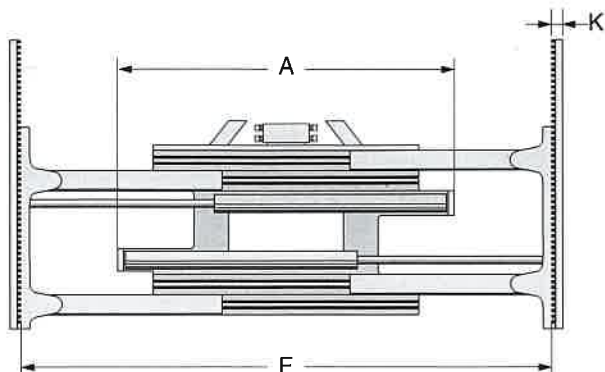

■ facing of inner arms:
super grip rubber
(see page 55)

including pressure relief valve, steplessly adjustable between 30-120 bar.

type	capacity	load centre	mounting class	for FLT	capacity max.	chassis width	arm carrier	opening range	arm width	arm height	arm length	l/c	cog	weight
	Q kg	lc mm	ISO class	t/lc	A mm	D mm	F mm	K mm	H mm	L mm	C mm	E mm	M kg	
a	3-0301N	700	500	2	1,5/500	980	40	530-1750	20	700	700	106	200	325
b	3-0301N	700	500	2	1,5/500	980	40	310-1310	20	800	800	106	270	365
a	3-0302N**	1000	500	2	1,5/500	880	40	450-1500	20	1050	700	106	150	300
b	3-0302N**	1000	500	2	1,5/500	880	40	520-1640	20	1050	700	106	240	330
c	3-0302N	1000	500	2	1,5/500	980	40	520-1740	20	1050	700	106	230	340
d	3-0302N	1000	500	2	1,5/500	980	40	620-1940	20	1050	700	106	230	340
e	3-0302N	1000	500	2	1,5/500	1080	40	520-1840	20	1050	700	106	220	350
f	3-0302N	1000	500	2	1,5/500	1080	40	620-2040	20	1000	900	106	220	440
g	3-0302N	1000	500	2	1,5/500	1380	40	620-2340	20	1050	700	106	200	380
h	3-0302N	1000	500	2	1,5/500	1380	40	700-2490	20	880	600	106	120	370
a	3-0303N	1600	500	2	2,0/500	980	40	485-1705	45	1000	1100	110	165	440
b	3-0303N	1600	500	2	2,0/500	980	40	370-1590	96	1200	1200	110	165	410
c	3-0303N	1600	500	2	2,0/500	980	40	370-1590	96	1150	1380	110	165	450
d	3-0303N	1600	500	2	2,0/500	1080	40	485-1805	45	1000	1100	110	165	450
e	3-0303N	1600	500	2	2,0/500	1080	40	370-1690	96	1200	1200	110	165	420
f	3-0303N	1600	500	2	2,0/500	1080	40	370-1690	96	1150	1380	110	165	470
g	3-0303N	1600	500	2	2,5/500	1380	40	470-2190	96	1150	1380	115	170	520

** suitable for reach trucks

Important

- additional hydraulics required
> one
> two, if sideshift required
- the unit has an integral sideshift with a pressure relief valve
- a pressure relief valve protects the unit against pressures exceeding 120 bar
- facing of the inner arms: super grip rubber
- hydraulic flow: type 3-0301N - 20 l/min, 3-0302N - 20 l/min

Options

available on request, see accessories page 83

- other arm lengths and openings
- various facings of the inner arms
- alternatively with a built-on sideshift
- loadguard
- pressure measuring device
- quick release lower hooks
- 3-position relief valve, lever type
- 4-position relief valve, solenoid control including visual control light indicators